



Inhaltsverzeichnis

P Bolzenschweißpistole

P.1.1.2 Bolzenschweißpistole SK 14 iso

P.1.2.1 Bolzenschweißpistole K 22

P.1.2.2 Bolzenschweißpistole K 22 D

....P.1.2.3 Bolzenschweißpistole K22 Alu

P.1.3.1 Bolzenschweißpistole K 24

Table of Contents

P Stud Welding Guns

P.1.1.2 stud welding gun SK 14 iso

P.1.2.1 stud welding gun K 22

P.1.2.2 stud welding gun K 22 D

P.1.2.3 stud welding gun K22 alu

P.1.3.1 stud welding gun K 24

Bolzenschweißpistole Sk 14 iso

Stud Welding Gun Sk 14 iso

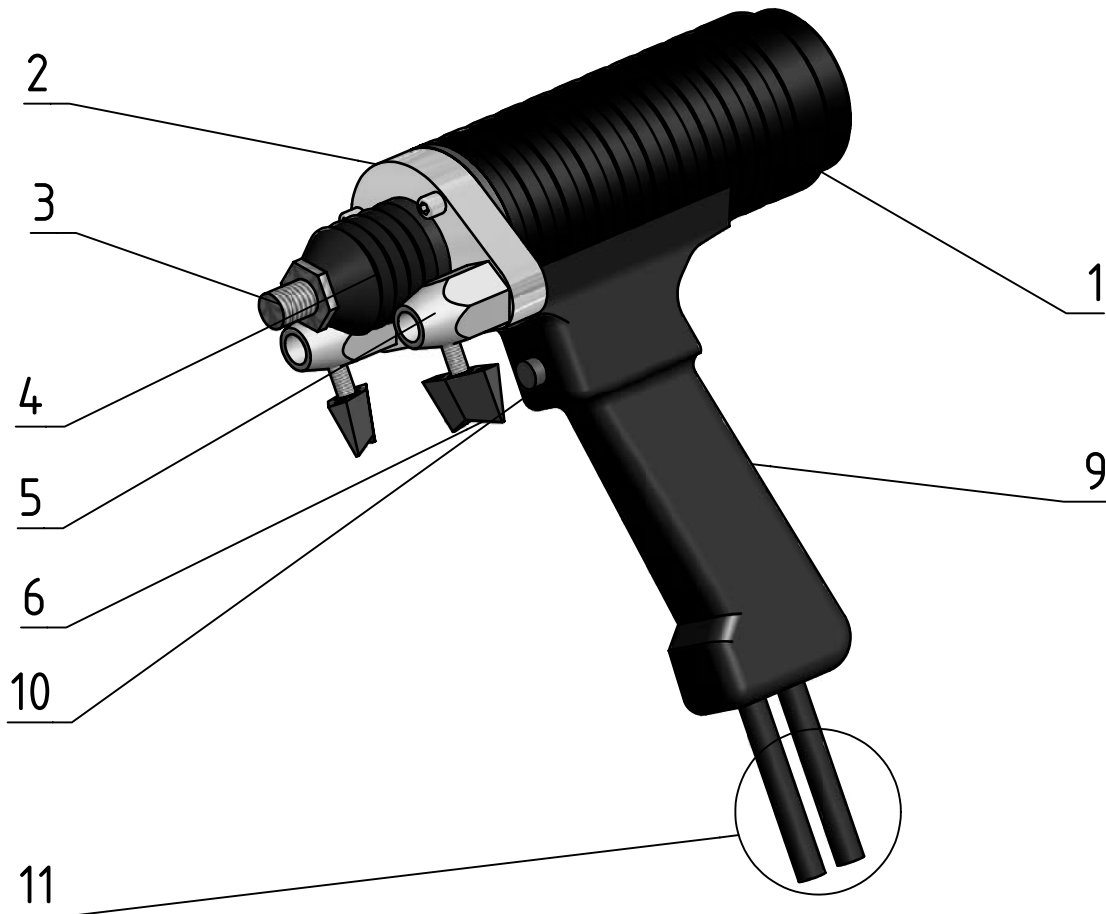

Pos item	Anzahl no. of units	Bezeichnung description	Bestell-Nr. order no.
1	1	Pistolengehäuse welding gun body	H35 768
2	1	Flanschplatte face plate	H35 817
3	1	Adapterschraube connecting screw	H35 818
4	1	Faltenbalg bellows	H10 911
5	2	Säulenklammung tensioning ring	H35 816
6	2	Flügelschraube wind screw	H00 048
9	1	Griffschale moulded	H35 770
10	1	Drucktaster push button	H35 727
11	1	Anschlusskabel komplett 5m - 35mm ² complete connection cable set 5m - 35mm ²	H35 783

Bolzenschweißpistole K22

Stud Welding Gun K 22

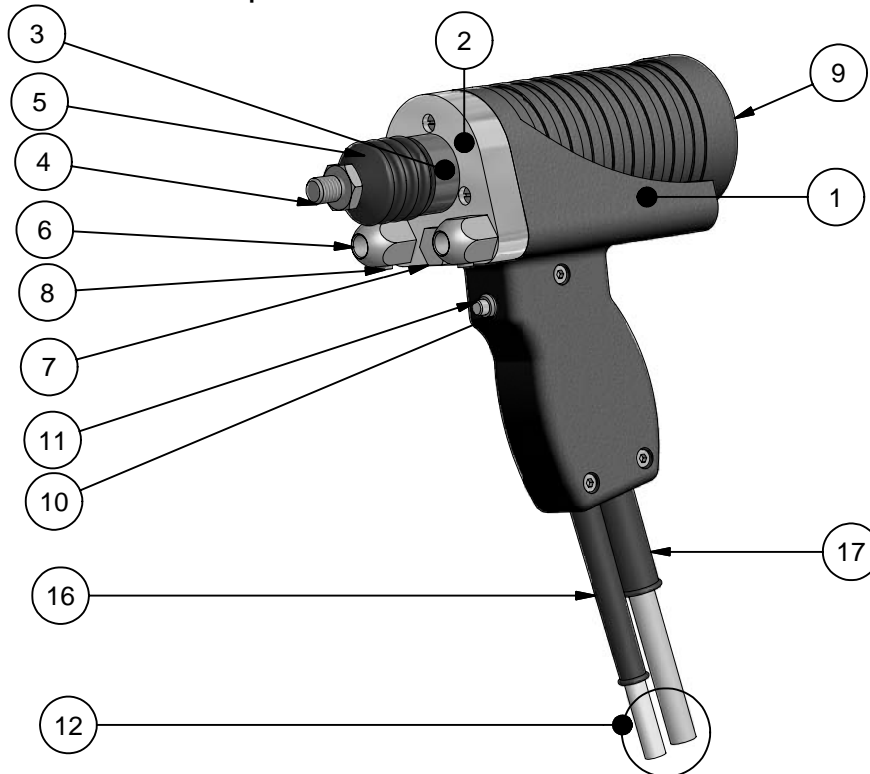

Pos item	Anzahl no. of units	Bezeichnung description	Bestell-Nr. order no.
1	1	Pistolengehäuse gun body	H35 013
2	1	Montageplatte mounting plate	H12 002
3	1	Kolbengehäuse piston cylinder	H35 095
4	1	Adapterschraube adapter screw	H10 910
5	1	Faltenbalg bellows	H10 911
6	2	Säulenklammung tensioning ring	H11 849
7	1	Verschlussschraube locking screw	H14 308
8	2	Innensechskantschraube M6x8 set screw M6x8	H11 356
9	1	Abschlußkappe rear cap	H11 359
10	1	Schaltlager switch pin bearing	H11 583
11	1	Schaltstift switch pins	H11 582
12	1	Anschlußkabel komplett 2m - 50mm ² complete connection cable set 2m - 50mm ²	H35 425
16	1	Knickschutz safety against buckling	H11 971
17	1	Knickschutz safety against buckling	H12 629

Bolzenschweißpistole K 22D

Stud Welding Gun K 22D

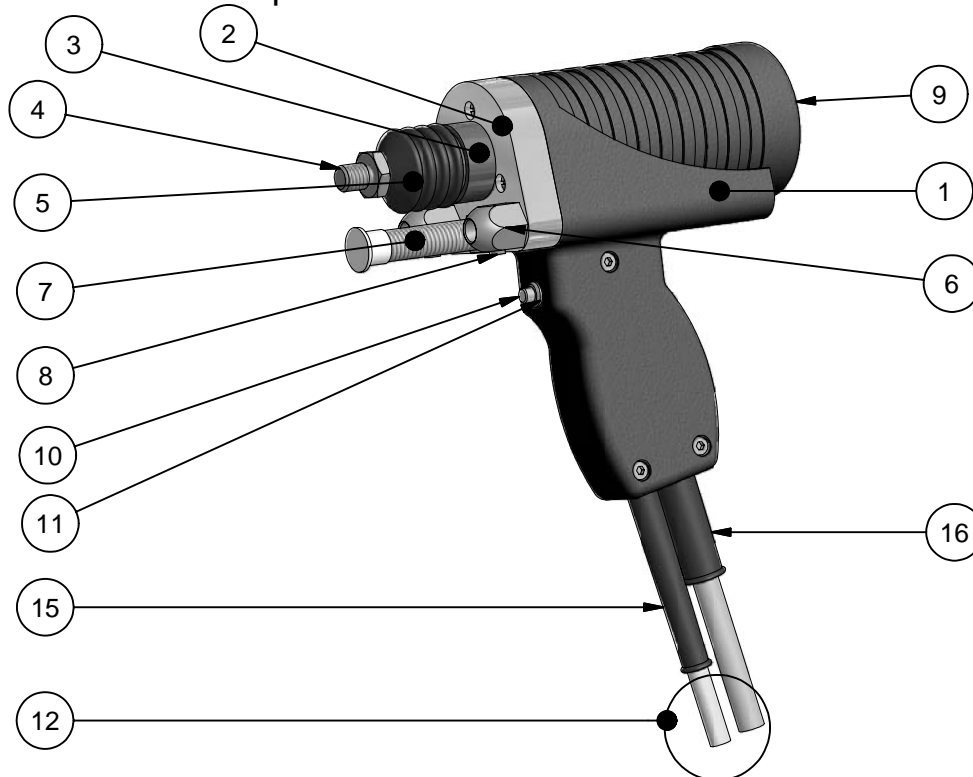

Pos item	Anzahl no. of units	Bezeichnung description	Bestell-Nr. order no.
1	1	Pistolengehäuse gun body	H35 013
2	1	Montageplatte mounting plate	H12 002
3	1	Kolbengehäuse piston cylinder	H35 095
4	1	Adapterschraube adapter screw	H10 910
5	1	Faltenbalg bellows	H10 911
6	2	Säulenklemmung tensioning ring	H11 849
7	1	Dämpfung damper	H11 992
8	2	Innensechskantschraube M6x8 set screw M6x8	H11 356
9	1	Abschlußkappe rear cap	H11 359
10	1	Schaltlager switch pin bearing	H11 583
11	1	Schaltstift switch pins	H11 582
12	1	Anschlußkabel komplett 2m - 50mm ² complete connection cable set 2m - 50mm ²	H35 425
15	1	Knickschutz safety against buckling	H11 971
16	1	Knickschutz safety against buckling	H12 629

Bolzenschweißpistole K22 Alu

Stud Welding Gun K22 alu

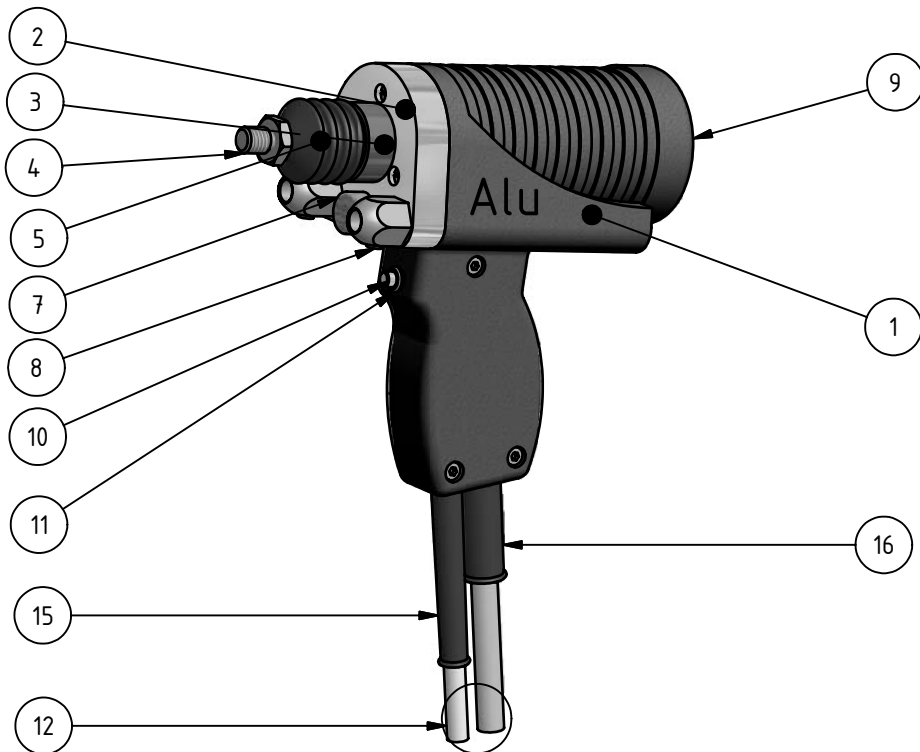

Pos item	Anzahl no. of units	Bezeichnung description	Bestell-Nr. order no.
1	1	Pistolengehäuse gun body	H35 013
2	1	Montageplatte mounting plate	H12 002
3	1	Kolbengehäuse piston cylinder	H35 095
4	1	Adapterschraube adapter screw	H10 910
5	1	Faltenbalg bellows	H10 911
6	2	Säulenklemmung tensioning ring	H11 849
7	1	Dämpfung damper	H35 741
8	2	Innensechskantschraube M6x8 set screw M6x8	H11 356
9	1	Abschlußkappe rear cap	H11 359
10	1	Schaltlager switch pin bearing	H11 583
11	1	Schaltstift switch pins	H11 582
12	1	Anschlußkabel komplett 2m - 50mm ² complete connection cable set 2m - 50mm ²	H35 425
15	1	Knickschutz safety against buckling	H11 971
16	1	Knickschutz safety against buckling	H12 629

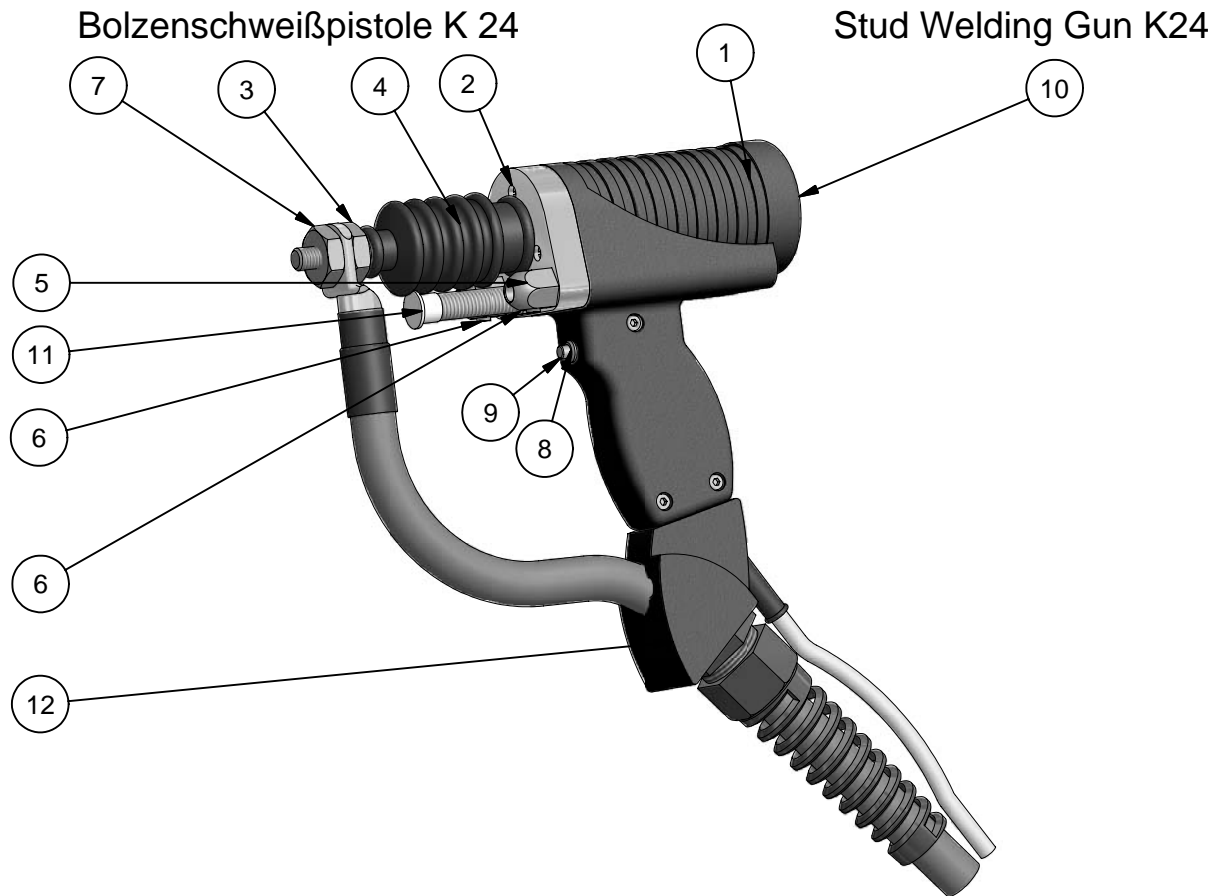

Pos item	Anzahl no. of units	Bezeichnung description	Bestell-Nr. order no.
1	1	Pistolengehäuse gun body	H12 001
2	1	Montageplatte mounting plate	H12 002
3	1	Adapterschraube adapter screw	H11 338
4	1	Faltenbalg bellows	H11 351
5	2	Säulenklammerung tensioning ring	H11 849
6	2	Innensechskantschraube M6x8 set screw M6x8	H11 356
7	1	Kontermutter locking nut	H11 346
8	1	Schaltlager switch pin bearing	H11 583
9	1	Schaltstift switch pins	H11 582
10	1	Abschlußkappe rear cap	H11 359
11	1	Dämpfung damper stop	H11 992
12	1	Anschlußkabel komplett 2m - 95mm ² complete connection cable set 2m - 95mm ²	H14 368