

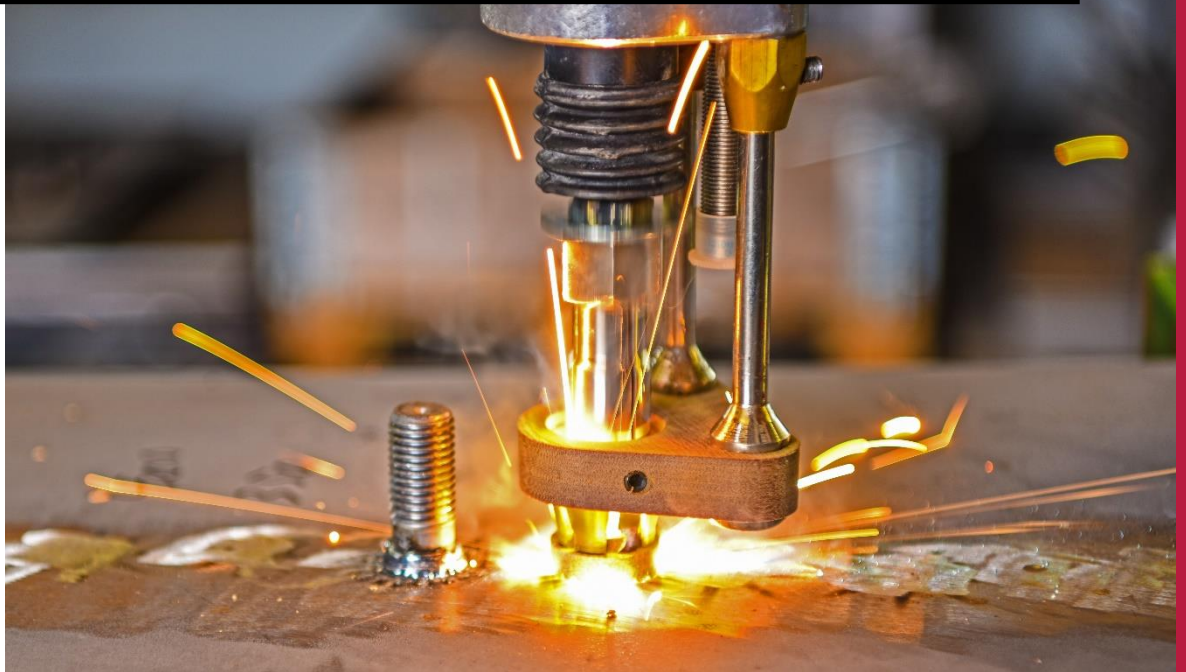

HIGH SPEED FASTENING SYSTEMS with stud welding



Ausgabe: 2021 insulation

Sprache: English



Table of Contents

application example type insulation pin IS.....	2
insulation pin type IS for steel-or Cr-Ni-construction	3
application example type bimetal pin VBS.....	4
bimetal type VBS für aluminium construction	5
application example type clip R and clip WN	6
clip type R	7
clip WN and SN with metal inlay for fire safety	8
cupped head pin (pin insulated).....	9
glue fixing pin	10

other materials or dimensions on request



application example type insulation pin IS



Easy and safe welding of insulation pins using drawn arc welding according to EN ISO 14555

Almost no heat input into base material when welding insulation pins

For use in steel construction or Cr-Ni-construction

Welding without restriction is possible in all the usual stud welding positions (floor, wall, ceiling)

Good conservation properties possible due to small diameter of the insulation pins

Shock resistant

Fast and easy installation of insulation wool through insulation pins and according clips /caps.

Fast and high flexibility for our customers' requirements through our production facility in Germany

Available in diameter 3mm, 4mm and 5mm



insulation pin type IS for steel-or Cr-Ni-construction

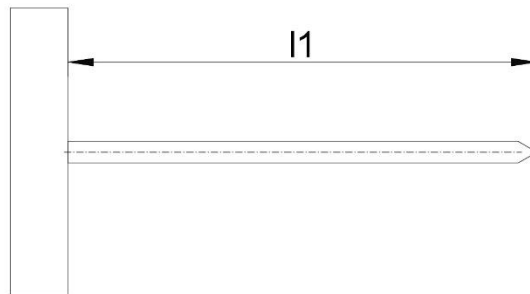
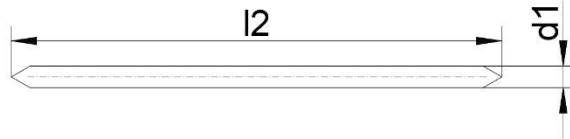
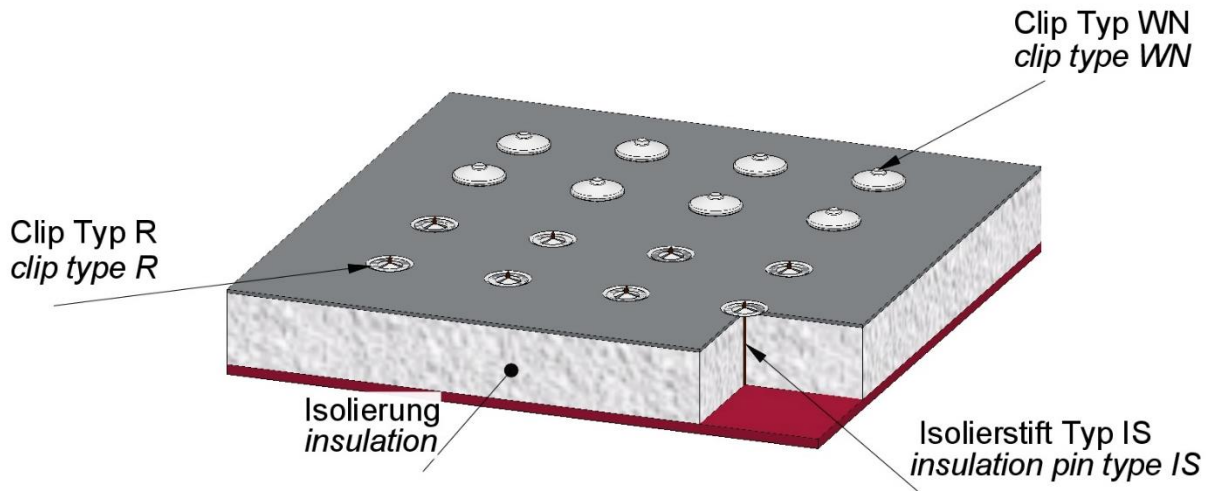

d1	3	4	5
l1+1	25-500	25-500	25-500
l2	l1+3	l1+3	l1+3

material

- copper plated steel
 - Chrom-Nickel-steel 1.4571
 - galvanised steel (A2K)
- other materials or dimensions on request

K2021-3-E-i

Hilbig GmbH • Postweg 204 • 21218 Seevetal • Germany



application example type bimetal pin VBS



Easy and safe welding of insulation pins using drawn arc welding according to EN ISO 14555

Almost no heat input into base material when welding insulation pins

For use in steel construction or Cr-Ni-construction

Welding without restriction is possible in all the usual stud welding positions (floor, wall, ceiling)

Good conservation properties possible due to small diameter of the insulation pins

Shock resistant

Fast and easy installation of insulation wool through insulation pins and according **clips /caps**.

Fast and high flexibility for our customers' requirements through our production facility in Germany

Available in diameter 3mm, 4mm and 5mm



bimetal type VBS for aluminium construction

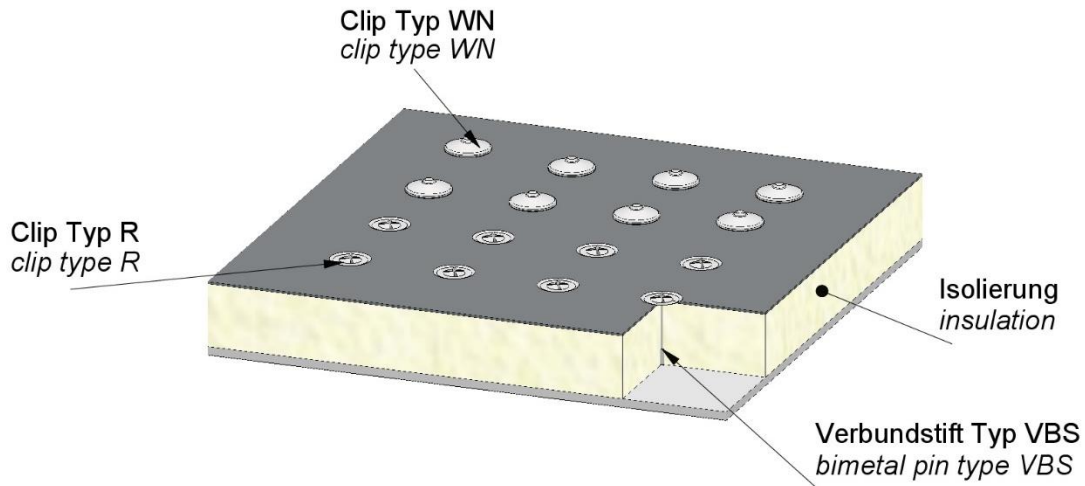

Aluminium
aluminum

Stahl verzinkt gerändelt oder 1.4571
gavanised steel, rough surface or 1.4571

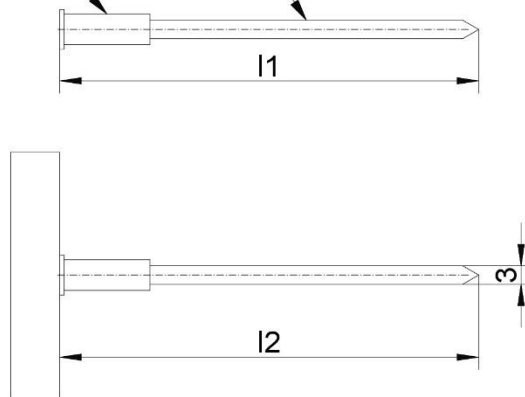

$l1 \pm 1$	25-300
$l2$	$l1-2,5$



application example type clip R and clip WN



Easy and secure fastening of insulation wool through a combination of previously welded insulation pins / VBS pins and clips fitting exactly to the diameter of the welded insulation pins / VBS pins.

Fast and easy application of clips by pressing the clips onto the end of welded insulation pins.

Clips are available and in stock in galvanized steel, and CR-Ni steel for diameters 2,7mm (suitable for glue fixing pins), 3mm, 4mm and 5mm

Thanks to our well stocked warehouses in Germany, we have all variations and diameters of clips available immediately for delivery.

Fast and high flexibility for our customers' requirements through our production facility in Germany

Fire resistant, halogen-free clips with different available plastic coating colors are available and in stock for diameters 2,7mm (suitable for glue fixing pins), 3mm, 4mm and 5mm



clip type R

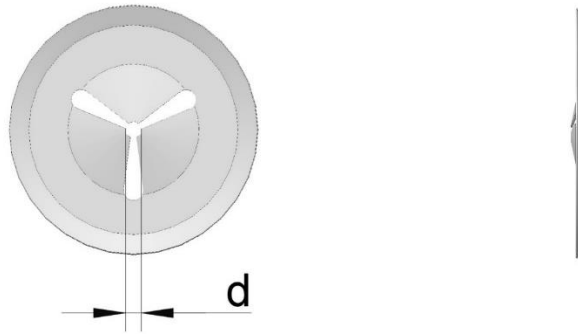

description	d	part-no.	PU	material
Clip 2,7R	2,7	H25052	6000	galvanized steel
		H25550		A4
Clip-3R	3	H10003		galvanized steel
		H10013		A4
Clip-4R	4	H10004		galvanized steel
		H10014		A4
Clip-5R	5	H10005		galvanized steel
		H10015		A4

other materials or dimensions on request



clip WN and SN with metal inlay for fire safety

*Inlay
inlay*

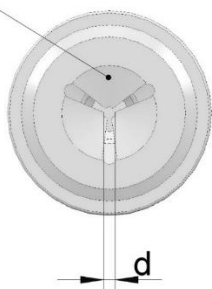

*Kappe
cap*



Description	d	Part-no.	PU	material inlay	material cap	colour cap
Clip 2,7WN	2,7	H25206	2000	galvanized steel	plastic, halogen free, self-extinguishing	white
		H25042		A4		
Clip-3WN	3	H13738		galvanized steel	plastic, halogen free, self-extinguishing	white
Clip-3SN		H25496		galvanized steel -		
Clip-3WN		H13741		A4	plastic, halogen free, self-extinguishing	white
Clip-3SN		H25212		1.4301		
Clip-4WN	4	H25085		galvanized steel	plastic, halogen free, self-extinguishing	white
Clip-4SN		H16996		galvanized steel -		
Clip-4WN		H25120		A4	plastic, halogen free, self-extinguishing	white
Clip-4SN		H25478		1.4301		
Clip-5WN	5	H13739		galvanized steel	plastic, halogen free, self-extinguishing	white
Clip-5SN		H16900		galvanized steel		
Clip-5WN		H13740		A4	plastic, halogen free, self-extinguishing	white
Clip-5SN		H25156		1.4301		

other materials or dimensions on request

K2021-8-E-i

Hilbig GmbH • Postweg 204 • 21218 Seevetal • Germany



cupped head pin (pin insulated)

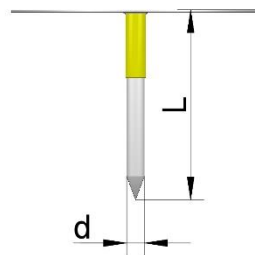
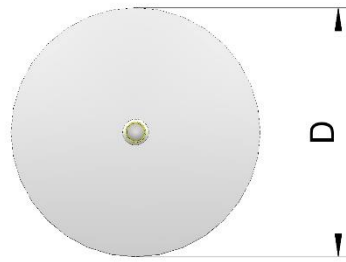

pin	$\emptyset 2, \emptyset 2,7\text{mm}$
plate	$d=\emptyset 2 \rightarrow D=30\text{mm}$ $d=2,7 \rightarrow D=38\text{mm}$
length	$\emptyset 2 \rightarrow L=9,5-54\text{mm}$ $\emptyset 2,7 \rightarrow L=9,5-152,4\text{mm}$
material	StZn A2

other materials or dimensions on request

K2021-9-E-i

Hilbig GmbH • Postweg 204 • 21218 Seevetal • Germany



glue fixing pin

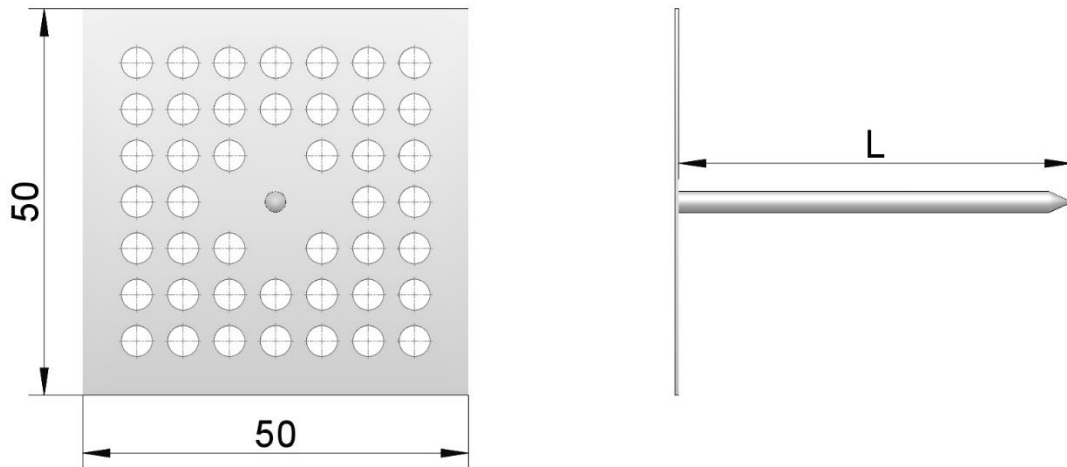

plate	50x50x0,5mm StZn, Cr-Ni-steel
pin	Ø2,7 steel copper plated, Cr-Ni-steel
length	L=25-203mm
adhesive surface	1950mm ²

Glue Fixing Pin

Easy and secure fastening of insulation wool through subsequent glueing of glue fixing pins on to prepared surfaces.

For use in steel construction, Cr-Ni-construction and aluminium construction

Fast and easy application of clips by pressing the clips onto the end of subsequently glued fixing pins.

Suitable clips are available in galvanized steel and CR-Ni steel in diameter 2,7mm (not included in delivery of glue fixing pins)

Thanks to our well stocked warehouses in Germany, we can offer consistent, fast and high flexibility

other materials or dimensions on request

K2021-10-E-i

Hilbig GmbH • Postweg 204 • 21218 Seevetal • Germany